

**E****MARINE MILITARY SUB-ACCESS  
ELECTRIC CONVECTION OVEN**

JOB NAME: \_\_\_\_\_

ITEM NO.: \_\_\_\_\_

NO. REQUIRED: \_\_\_\_\_

**MODELS**

- MSA-SB-2600** - Marine single electric convection oven
- MSA-SB-2692** - Marine double stack electric convection oven

**DESCRIPTION**

Will be a Market Forge Military Sub-Accessible High Efficiency Electric Convection Oven equipped with COOK & CONSTANT COOK controls. CONSTANT COOK permits operator to preset oven to cook food at a constant temperature for a infinite amount of time.

Exterior will be finished with stainless steel panels, top, rear, and sides. Oven liner will be wrapped with a minimum 0.75" (19mm) High-Grade insulation. French type doors will open a full 180° and will be Stainless steel with a minimum of 0.75" (19mm) insulation.

Oven interior dimensions will be 27-3/8" wide x 20" high x 24-5/8" deep (695mm wide x 508mm high x 625mm deep). Oven interior will be stainless steel with coved corners and a water-proof design. Oven shelves and shelf supports will provide nine shelf positions centered 2" (51mm) apart. Shelf stops on oven shelf will prevent tipping within the shelf supports. Five shelves will be furnished as standard. Safety door latch designed to keep doors closed in any pitch and roll environment is included.

Controls will be located on an embossed recessed panel on the right front of oven. Controls will include main power switch, thermostat with indicator light and temperature range of 200°-475°F (93°-246°C), electro-mechanical 60-minute and Constant cook timer with audible alarms that sound at end of the preset interval. A 2-speed fan selector switch with HIGH or LOW modes. Controls will also include a high limit cut-off. Oven ships with (4) Flanged Feet as standard.

Convactor fan will turn on automatically when power is on and right door is closed. Fan will turn off automatically when right door is opened. For rapid cooling purposes, it will be possible to operate convactor fan with left door open in order to quickly evacuate heated air from oven. Convactor fan motor will be rated at 1/4 HP. Oven will be completely serviceable from the front.

**OPERATION WILL BE BY**

Oven will be rated at 11 kW, and equipped for operation on 440-480 VAC, 3 pH .

Oven controls will operate on nominal 120 volts AC.

**SHIPPING WEIGHT**

- MSA-SB-2600** - 350 lbs (159 kg)
- MSA-SB-2692** - 700 lbs (318 kg)

*MSA-SB-2600 shown***OPTIONS & ACCESSORIES**

(at additional charge)

- Extra Stainless Steel Shelves

**FOOD SERVICE EQUIPMENT**  
 Marine Electric Convection Oven
**MARKET FORGE**Tel: (802) 658-6600 • Fax: (802) 864-0183 • [www.marketforge.com](http://www.marketforge.com)

# E

## MARINE MILITARY SUB-ACCESS ELECTRIC CONVECTION OVEN

DETAILS & DIMENSIONS

### SERVICE CONNECTIONS

EC	Electrical Connection - Connection for incoming power supply wires on terminal block.
EP	Power Supply - 1 3/8 (44mm) Ø access holes for power supply wires. Use wire suitable for at least 90°C. Nominal amp per line wire per oven: 11kW.

### ELECTRICAL SPECIFICATIONS

VOLTS	1 pH	3 pH
480 (440-480)	---	15

DIMENSIONS ARE IN INCHES [MM]

FOOD SERVICE EQUIPMENT  
Marine Electric Convection Oven

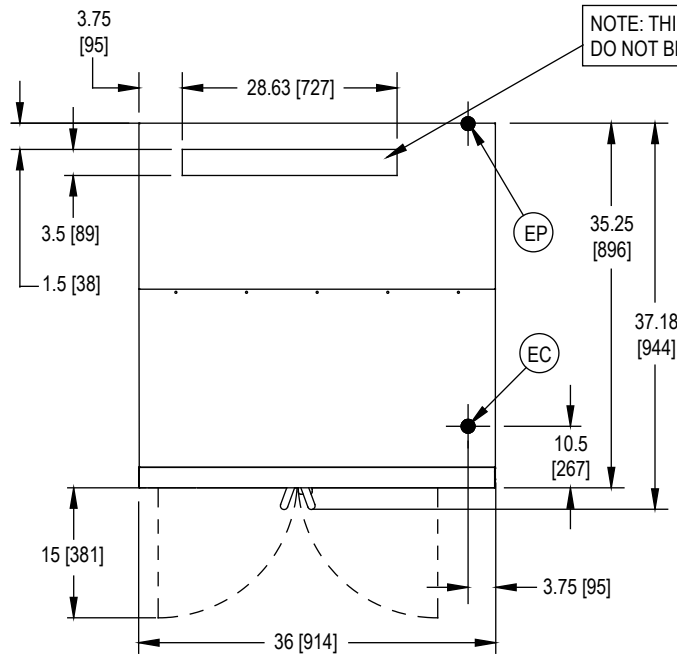

NOTE: THIS OPENING MUST BE PROPERLY VENTED.  
DO NOT BLOCK OR RESTRICT AIRFLOW.

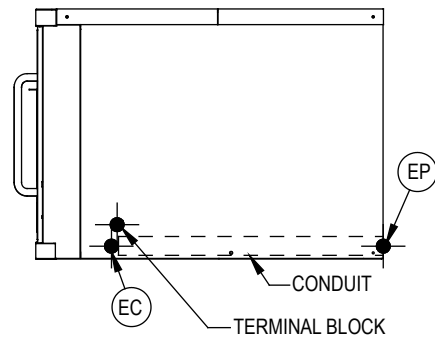
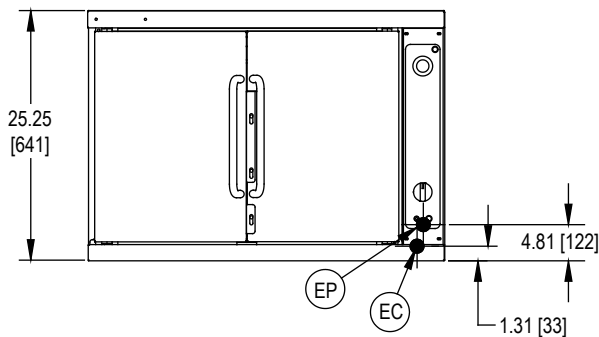
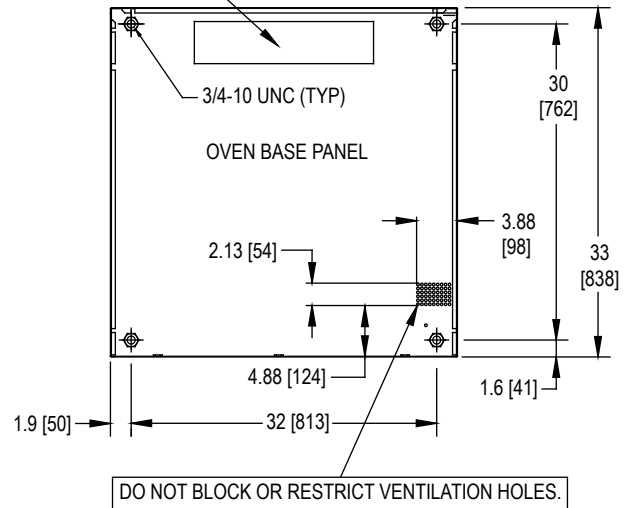

The manufacturer reserves the right to modify materials and specifications without notice.