



MODEL	CAPACITY	
UCBTE048V1	48 Gallon	180 Liter

SPECIFICATIONS:

Cooking vessel in stainless steel AISI 304 (bottom thickness 12 mm and wall thickness 3 mm). Vessel with electric tilting on front part.

Lid in stainless steel AISI 304 (thickness 20/10), with double cover and ergonomic handle Balanced by means of gas springs.

Self-supporting frame in stainless steel AISI 304 (thickness 30-40/10) Outer cover in stainless steel AISI 304, fine satin finish (thickness 12-15/10)

Adjustable feet in stainless steel AISI 304 to ensure levelling, with removable cover for cleaning operations. Fast accessibility to the main functional parts (electronic card, fuses, thermostats...) only removing the frontal panels

Protection level IPX5.

OPERATION SHALL BE BY:

- Heating by means of armored elements in INCOLOY-800 alloy controlled by electronic board.
- Temperature control by system with two probes (product/bottom)
- Automatic mixing device with three arms and PTFE scrapers, completely removable to make cleaning easier, with regulation directly from the control panel according to the product to be processed.
- Electronic control by means of multifunctional keyboard with Touch Screen 7" and easy and clear messages.
- USB connection to download HACCP data, update the software and load cooking programs.
- Ability to interrogate the machine using communication protocol MODBUS over RS485 serial interface.
- Connection for power economizer

OPTIONS and ACCESSORIES:

- Cleaning shower for UCBT/PR (CADE0010)
- Kit wheels PR/UCBT/UDBR (D150)
- Strainer for UCBT.048 (PAF0901)
- Tri-clover sanitary fittings 2" (PAF2050)
- Tri-clover sanitary fittings 3" (PAF2060)

Job _____
Item# _____

Models: UCBTE048V1

* REG. 0 ; + 1 5/8"

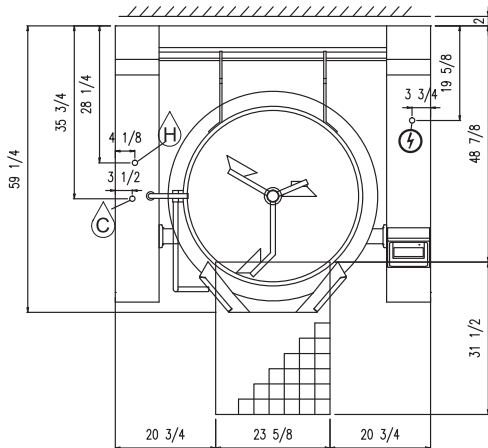
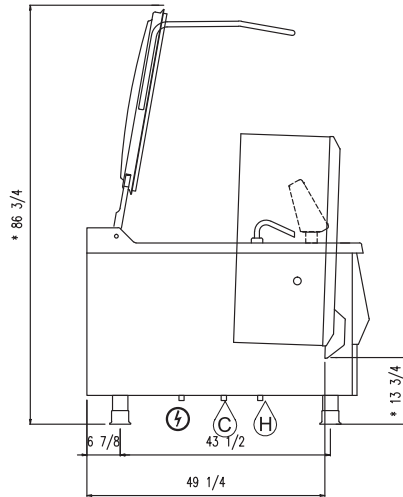
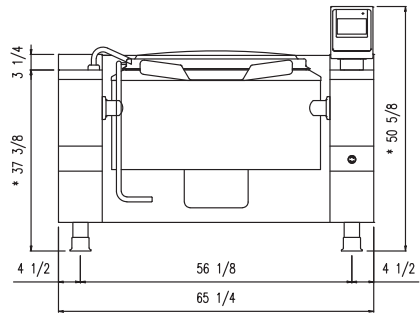

MODEL	WEIGHT	MINIMUM CLEARANCE	
		SIDES	BACK
UCBTE048V1	1246 (565)	SIDES	0" [0 mm]
		BACK	2" [51 mm]

ELECTRICAL CHARACTERISTICS

MODEL	AMPS PER LINE			
	PHASE	KW	208V	220-240V
UCBTE048V1	3	19.3	53.6	N/A
	3	19.3	N/A	46.5

- Field Wire Electrical Connection to be as specified on rating plate.
- COLD WATER: 3/4" O.D. tubing at 25-50 PSI(170-345 kPa)
- HOT WATER: 3/4" O.D. tubing at 25-50 PSI(170-345 kPa).

**INTENDED FOR COMMERCIAL USE ONLY.
NOT FOR HOUSEHOLD USE.**



70 Oakdale Road, Toronto ON, Canada M3N 1V9
(919) 762-1000 www.crownsteam.com