

FULL JACKET ELECTRIC STEAM TILTING KETTLE



- ELT-20F
- ELT-30F
- ELT-40F
- ELT-60F

OPERATION SHALL BE BY:

Electrically, self-generating closed steam system operating at 50 psi equipped for operation on:

- 08 VAC, 1 phase, 50/60 Hz (12 to 18 kW only)
- 208 VAC, 3 phase, 50/60 Hz
- 220 VAC, 1 phase, 50/60 Hz (12 to 18 kW only)
- 220 VAC, 3 phase, 50/60 Hz
- 240 VAC, 1 phase, 50/60 Hz (12 to 18 kW only)
- 240 VAC, 3 phase, 50/60 Hz
- 380/220 VAC, 3 phase, 4 wire, 50/60 Hz
- 415/240 VAC, 3 phase, 4 wire, 50/60 Hz

OPTIONS & ACCESSORIES AT ADDITIONAL COST

- | | | |
|---|---|--|
| <input type="checkbox"/> 380 VAC, 3 phase, 50/60 Hz. | <input type="checkbox"/> 2" (50 mm) draw-off valve (TVT-2) | <input type="checkbox"/> Contoured measuring strip |
| <input type="checkbox"/> 415 VAC, 3 phase, 50/60 Hz. | <input type="checkbox"/> 3" (76 mm) draw-off valve (TVT-3) | <input type="checkbox"/> Strainer hook (SH-) |
| <input type="checkbox"/> 480 VAC, 3 phase, 50/60 Hz. | <input type="checkbox"/> Single pantry faucet with an 18" swing spout (SF-18) | <input type="checkbox"/> Pan support (PC-4) |
| <input type="checkbox"/> 600 VAC, 3 phase, 50/60 Hz. | <input type="checkbox"/> Double pantry faucet with an 18" swing spout (DF-18) | <input type="checkbox"/> Pour lip strainer (TKS-) |
| <input type="checkbox"/> 24 kW on 40, 60 gallon | <input type="checkbox"/> Single pantry faucet with 18" swing spout and 68" spray hose and bracket (SP-RSH-18) | <input type="checkbox"/> Draw-off valve hose kit (DVHK-) |
| <input type="checkbox"/> 33 kW on 30, 60 gallon | <input type="checkbox"/> Double pantry faucet with 18" swing spout and 68" spray hose and bracket (DP-RSH-18) | <input type="checkbox"/> Calibrated thermostat dial, "F" |
| <input type="checkbox"/> Spring assist hinged stainless steel cover (CH-) | <input type="checkbox"/> One piece lift off stainless steel cover (C-) | <input type="checkbox"/> Calibrated thermostat dial, "C" |
| <input type="checkbox"/> Etched gallon markings (GM-) | <input type="checkbox"/> Triple basket assembly | <input type="checkbox"/> Kettle heat shield (KHS-) |
| <input type="checkbox"/> Etched litre markings (LM-) | <input type="checkbox"/> Perforated strainer for draw off (TPS-) | |
| <input type="checkbox"/> Correctional package | <input type="checkbox"/> Solid disc for draw off (TSS-) | |

STANDARD CONSTRUCTION SPECIFICATIONS

Shall be a Southbend Steam model ELT-20F, ELT-30F, ELT-40F, ELT-60F, self-generating, electric tilting full jacket kettle, low height.

A double wall kettle interior shall form a steam jacket around the kettle.

The jacket enclosure shall contain distilled water which is factory sealed.

The bottom of the kettle shall be of hemispherical design for superior heat circulation.

The console shall be drip proof, stainless steel clad and shall be supported on all welded 1-5/8" (41 mm) diameter stainless steel pipe frame and the legs fitted with 4 hole adjustable feet for securing to the floor.

The kettle shall pivot on trunnion connected to the tilt mechanism and the out-bore bearing connected to the frame and shall permit

the kettle to tilt forward a full 90° for complete emptying.

The tilt mechanism shall be self locking for positive stop action.

Construction shall be all welded #4 finish stainless steel, type 304.

The kettle liner shall be standard with type 316 for high acid content cooking.

The controls shall be integrally mounted and shall include a power switch, thermostat, pilot light, low water light, vacuum/pressure gauge, safety relief valve, and low water shut off.

The kettle shall be standard with removable elements.

The kettle shall operate in a temperature range of 165°F to 285°F (74°C to 140°C) at a maximum pressure of 50 psi (345 kPa).



Approval Notes: _____

ELT-F

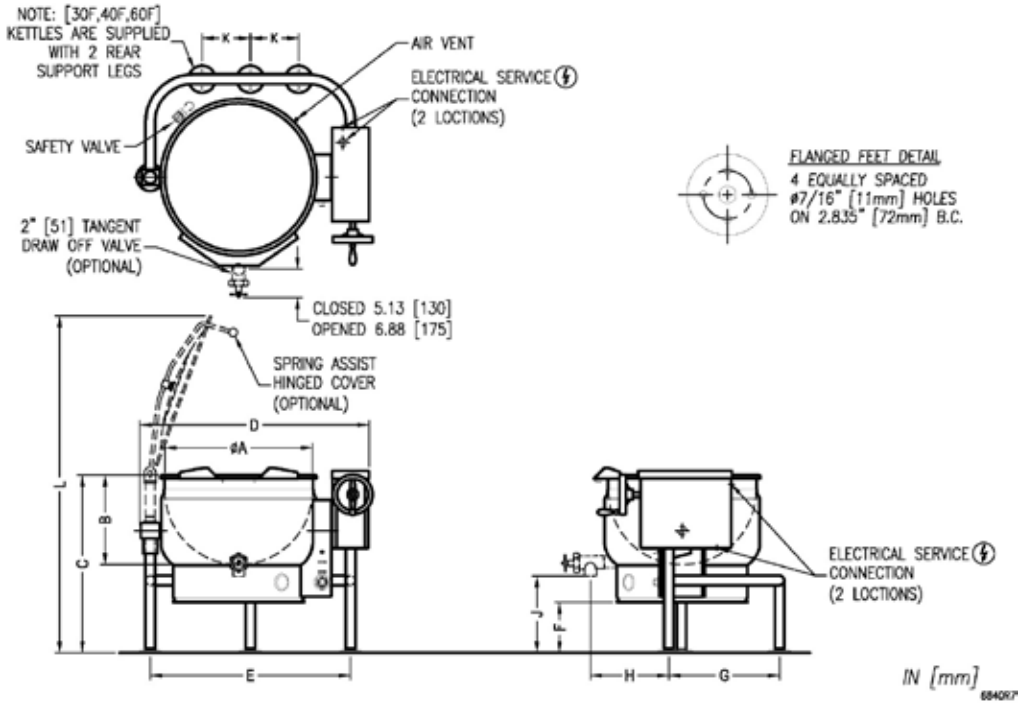

SERVICE CONNECTIONS

⚡ – ELECTRICAL CONNECTION : To be as specified on data plate.

DIMENSIONS

MODEL	CAPACITY	UNITS	A	B	C	D	E	F	G	H	J	K	L
ELT-20F	20 gallons (76 liters)	in (mm)	26" (660)	15.75" (400)	31.25" (794)	40.38" (1026)	35.25" (895)	8.88" (225)	19.5" (495)	13.88" (352)	13.25" (337)	N/A	62" (1575)
ELT-30F	30 gallons (114 liters)	in (mm)	29.5" (749)	17.5" (445)	33.5" (851)	43.88" (1114)	38.75" (984)	9.63" (245)	22.25" (565)	15.38" (391)	13.5" (343)	10.5" (267)	67.5" (1715)
ELT-40F	40 gallons (152 liters)	in (mm)	33" (838)	19.25" (489)	36.25" (921)	47.13" (1197)	42" (1067)	11.25" (286)	23.75" (603)	17.13" (435)	14.5" (368)	12" (305)	73.75" (1873)
ELT-60F	60 gallons (227 liters)	in (mm)	35.5" (902)	20.5" (521)	39.25" (997)	50" (1270)	44.63" (1133)	12" (305)	25.25" (641)	17.88" (454)	16.5" (419)	13.5" (343)	79.5" (2019)

ELECTRICAL CHARACTERISTIC

AVAILABLE kW			AMPS PER LINE								
MODEL	STANDARD	OPTIONAL	kW	PHASE	208V	220V	240V	380V	415V	480V	600V
ELT-20F	18	N/A	18	1	86.5	81.8	75.0	N/A	N/A	N/A	N/A
ELT-30F	18	24 or 33		3	50.0	47.2	43.3	27.3	25.0	21.7	21.7
ELT-40F	18	24 or 33	24	3	66.6	63.0	57.7	36.5	33.4	28.9	23.1
ELT-60F	24	33	33	3	91.6	86.6	79.4	50.1	45.9	39.7	31.8

SPECIFICATIONS

MODEL	CAPACITY		MODEL	SHIPPING WEIGHT	MINIMUM CLEARANCE	
ELT-20F	20 Gallon	76 Liter	ELT-20F	340 lbs. [154 kg]	SIDES BACK	0 0
ELT-30F	30 Gallon	114 Liter	ELT-30F	402 lbs. [182 kg]		
ELT-40F	40 Gallon	152 Liter	ELT-40F	500 lbs. [227 kg]		
ELT-60F	60 Gallon	227 Liter	ELT-60F	610 lbs. [277 kg]		

**INTENDED FOR COMMERCIAL USE ONLY.
NOT FOR HOUSEHOLD USE.**

